

# MICA2

## WIRELESS MEASUREMENT SYSTEM

- ▼ 3rd Generation, Tiny, Wireless Platform for Smart Sensors
- ▼ Designed Specifically for Deeply Embedded Sensor Networks
- ▼ > 1 Year Battery Life on AA Batteries (Using Sleep Modes)
- ▼ Wireless Communications with Every Node as Router Capability
- ▼ 315, 433 or 868/916 MHz Multi-Channel Radio Transceiver
- ▼ Expansion Connector for Light, Temperature, RH, Barometric Pressure, Acceleration/Seismic, Acoustic, Magnetic, and other Crossbow Sensor Boards

## Applications

- ▼ Wireless Sensor Networks
- ▼ Security, Surveillance, and Force Protection
- ▼ Environmental Monitoring
- ▼ Large Scale Wireless Networks (1000+ points)
- ▼ Distributed Computing Platform



## MICA2

The MICA2 Mote is a third generation mote module used for enabling low-power, wireless, sensor networks. The MICA2 Mote features several new improvements over the original MICA Mote. The following features make the MICA2 better suited to commercial deployment:

- 868/916MHz, 433 or 315MHz multi-channel transceiver with extended range
- TinyOS (TOS) Distributed Software Operating System v1.0 with improved networking stack and improved debugging features
- Support for wireless remote reprogramming
- Wide range of sensor boards and data acquisition add-on boards
- Compatible with MICA2DOT (MPR500) quarter-sized Mote

TinyOS 1.0 is a small, open-source, energy efficient, software operating system developed by UC Berkeley which supports large scale, self-configuring sensor networks. The source code and software development tools are publicly available at:

<http://webs.cs.berkeley.edu/tos>

### Processor and Radio Platform (MPR400CB):

The MPR400CB is based on the Atmel ATmega128L. The ATmega128L is a low-power microcontroller which runs TOS from its internal flash memory. Using TOS, a single processor board (MPR400CB) can be configured to run your sensor application/processing and the network/radio communications stack simultaneously. The MICA2 51-pin expansion connector supports Analog Inputs, Digital I/O, I2C, SPI, and UART interfaces. These interfaces make it easy to connect to a wide variety of external peripherals.

### Sensor Boards:

Various sensor and data acquisition boards are available from Crossbow. These boards connect to the MICA2 through a surface mount 51-pin connector. Crossbow supplies the following sensor boards:

- MTS101CA Photocell/ Thermistor/Proto and Experiment Board
- MTS300CA/MTS310CA Photocell, Thermistor, Microphone, Sounder, Magnetic (310 only), Acceleration (310 only)
- Contact Crossbow for information on other boards

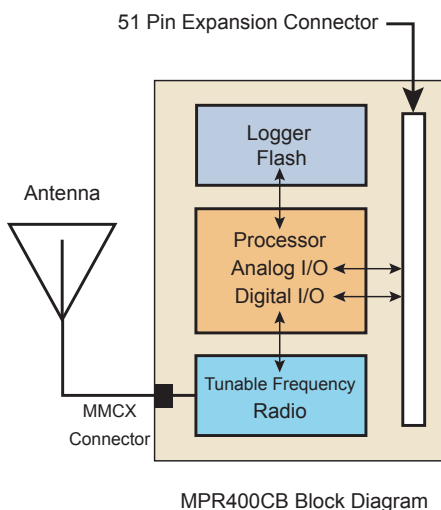

Processor/Radio Board	MPR400CB	MPR410CB	MPR420CB	Remarks
<b>Processor Performance</b>				
Program Flash Memory	128K bytes	128K bytes	128K bytes	
Measurement (Serial) Flash	512K bytes	512K bytes	512K bytes	>100,000 Measurements
Configuration EEPROM	4 K bytes	4 K bytes	4 K bytes	
Serial Communications	UART	UART	UART	0-3V transmission levels
Analog to Digital Converter	10 bit ADC	10 bit ADC	10 bit ADC	8 channel, 0-3Vin
Other Interfaces	DIO,I2C,SPI	DIO,I2C,SPI	DIO,I2C,SPI	
Current Draw	8 mA	8 mA	8 mA	active mode
	< 15uA	< 15 uA	< 15 uA	sleep mode
<b>Multi-Channel Radio</b>				
Center Frequency	868/916 MHz	433 MHz	315 MHz	ISM bands
Number of Channels	4 / 50	4	5	programmable, country specific
Data Rate	38.4 Kbaud	38.4 Kbaud	38.4 Kbaud	manchester encoded
RF Power	-20 to +5 dBm	-20 to +10 dBm	-20 to +10 dBm	programmable, typical
Receive Sensitivity	-98 dBm	-101 dBm	-101 dBm	typical, analog RSSI at AD Ch. 0
Outdoor Range	500 ft	1000 ft	1000 ft	1/4 Wave dipole, line of sight
Current Draw	27 mA	25 mA	25 mA	transmit with maximum power
	10 mA	8 mA	8 mA	receive
	< 1 uA	< 1 uA	< 1 uA	sleep
<b>Electromechanical</b>				
Battery	2X AA batteries	2X AA batteries	2X AA batteries	attached pack
External Power	2.7 - 3.3 V	2.7 - 3.3 V	2.7 - 3.3 V	connector provided
User Interface	3 LEDs	3 LEDs	3 LEDs	user programmable
Size (in)	2.25 x 1.25 x 0.25	2.25 x 1.25 x 0.25	2.25 x 1.25 x 0.25	excl. battery pack
(mm)	58 x 32 x 7	58 x 32 x 7	58 x 32 x 7	excl. battery pack
Weight (oz)	0.7	0.7	0.7	excl. batteries
(grams)	18	18	18	excl. batteries
Expansion Connector	51 pin	51 pin	51 pin	all major I/O signals

### Base Stations:

A base station allows the aggregation of sensor network data onto a PC or other computer platform. Any MICA2 node (MPR400CB) can function as a base station by plugging the MPR400CB processor/radio board into a standard PC interface board, known as the Mote Interface Board (MIB510CA). The MIB510CA provides a serial interface for RS-232 as well as a parallel port programming interface for the Motes.

Crossbow also offers a stand-alone gateway solution, the MIB600CA for TCP/IP-based Ethernet networks.

### ▼ MIB510CA Mote Interface Board

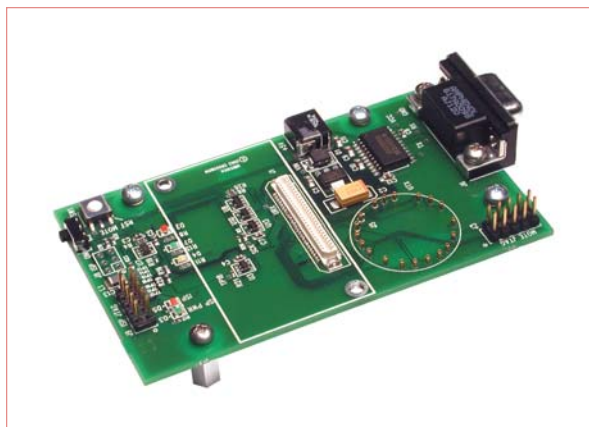

### Ordering Information

Model	Description
MOTE-KIT400	Multi-Channel Developer's Kit (3X MPR400CB, 2X MTS300CA, 1X MIB510CA)
MOTE-KIT410	Multi-Channel Developer's Kit (3X MPR410CB, 2X MTS300CA, 1X MIB510CA)
MOTE-KIT420	Multi-Channel Developer's Kit (3X MPR420CB, 2X MTS300CA, 1X MIB510CA)
MPR400CB	868/916 MHz Processor/Radio Board
MPR410CB	433 MHz Processor/Radio Board
MPR420CB	315 MHz Processor/Radio Board
MTS101CA	Light, Temp, and Prototype Sensor Board
MTS300CA	Light, Temp, Acoustic, and Sounder Sensor Board
MTS310CA	Same as MTS300CA but also includes Magnetic and Acceleration
MIB510CA	MICA, MICA2, MICA2DOT Mote Interface & Programming Board